



...and so, on the next day...

Viral Marketing

The kids hired Tara Lalezari to help with marketing. Of course, she's an expert in "Viral Marketing." They remember she said that marketing was all about connecting ideas, but they can't remember the one thing that would allow their idea to spread! She wrote it on one of the post-it notes, so if we could remember the big picture...

Note for playtesting: we intend for the self-sticky notes to be in a disorganized stack here on this page.

Received with this puzzle: one business card; this page; 9 self-sticky notes.



DASH 6 - Experienced Players

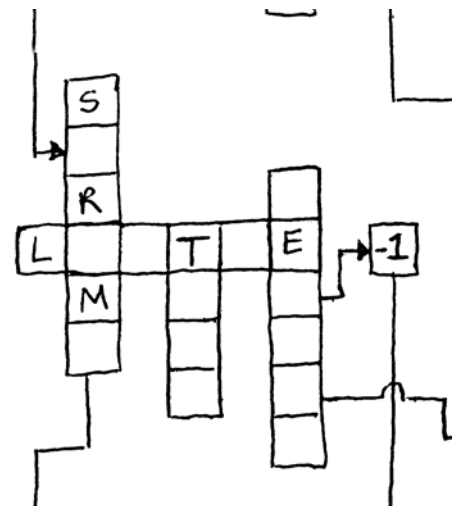
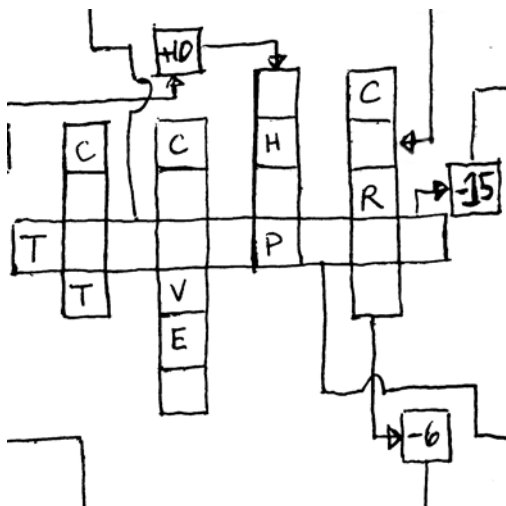
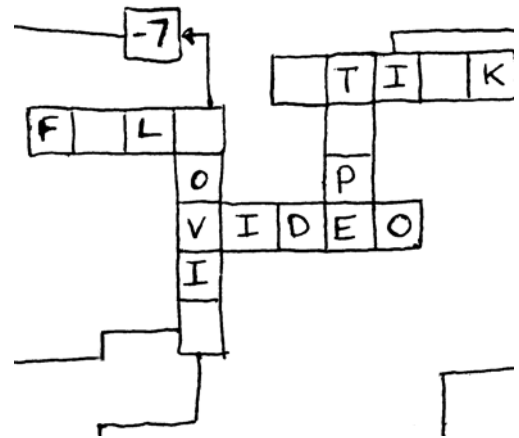
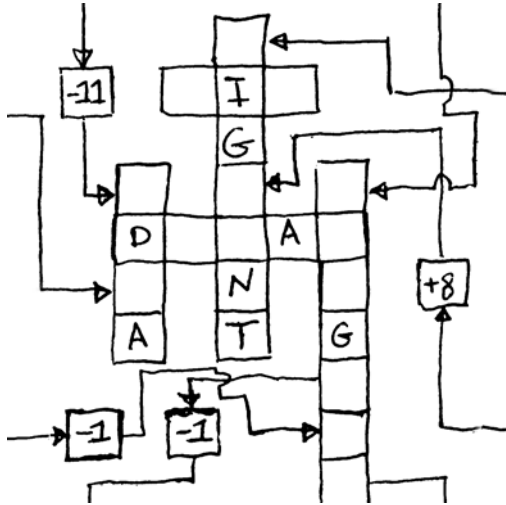

Note for playtesting: we intend for this puzzle to come already cut into 9 pieces, and that these squares will be Post-It style notes.

