



...and so, on the next day...

Mass Production

In your postal mail you're surprised to find a letter addressed to the kids. They're eager to open it and you read it over their shoulders.

Salutations Lemonade Stand Entrepreneurs,

I am DeShawn Quint, a business growth consultant from Stage. I am interested in helping you meet the increased demand for your fabulous lemonade.

After some research, I have discovered a local drink company that has declared bankruptcy. One of the assets that they are forced to liquidate is a bottling facility consisting of three buildings. Each building is already outfitted with three pipelines for transporting and processing your three ingredients (sugar, water, and lemon juice). I should also mention that the three pipelines pass through several raised vats along the way that contribute certain processes of hands-on inspection to ensure a quality product.

Unfortunately there are also extraneous pipelines in each facility that confuse the issue. We've consulted the four blueprints for the facility, but discovered that something terribly unprofessional has occurred: the interior diagrams for the three buildings were printed together on the same four pieces of paper. This complication will make it more difficult to locate the functioning production lines. Luckily we also discovered a bird's-eye view diagram illustrating how the blueprints are oriented and attached to each other for each of the three buildings. These diagrams have been attached to the bottom of this letter.

We have a contact at the site: Louis B. He specializes in the maintenance of the raised vats and may be able to help after you have located the three functioning pipelines for each building. He has a suggestion for how to make more money from your business at this location.

I think this site will be the best choice to further grow your business. If it is agreed that this bottling facility will fulfill your business needs; then we are ready to produce mass quantities of your fabulous lemonade.

Regards,

DeShawn Quint

DeShawn Quint

Business Consultant

Stage

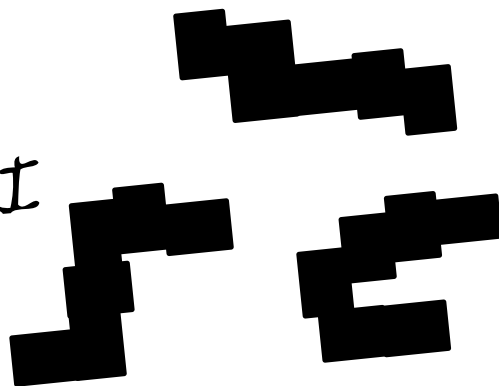

Received with this puzzle: one business card; this page; six printed sheets.



DASH 6 - Experienced Players

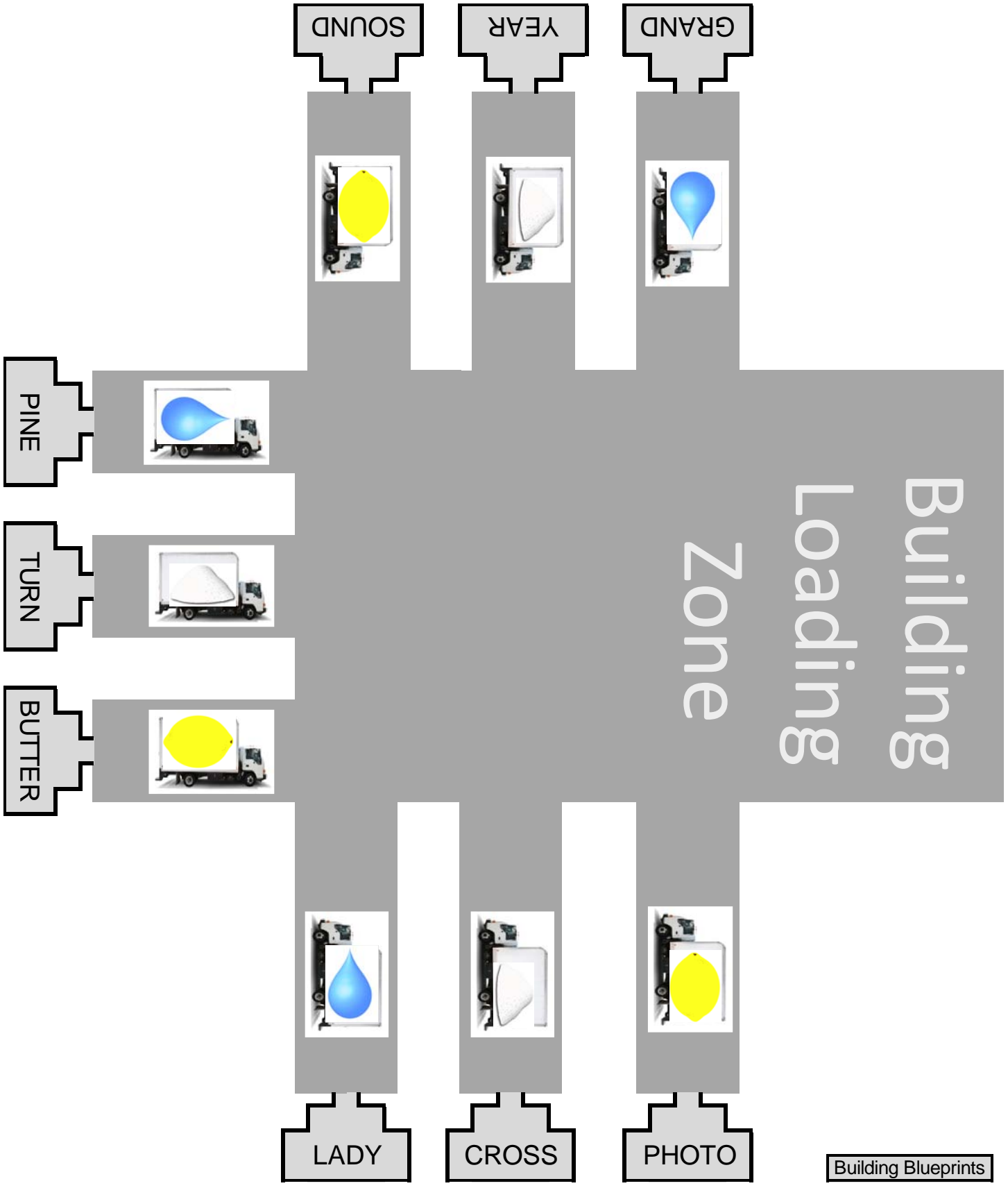

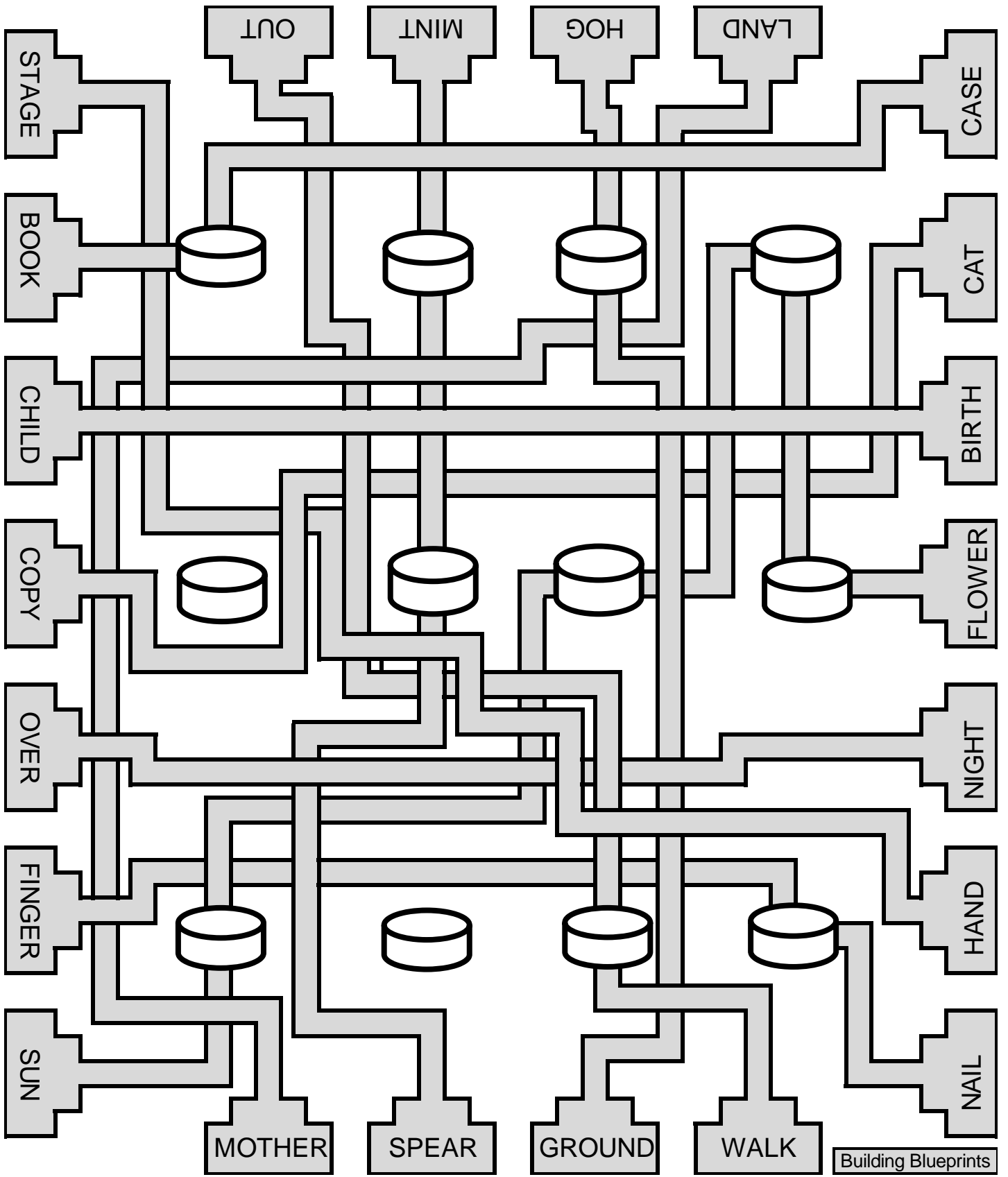

Building Blueprints

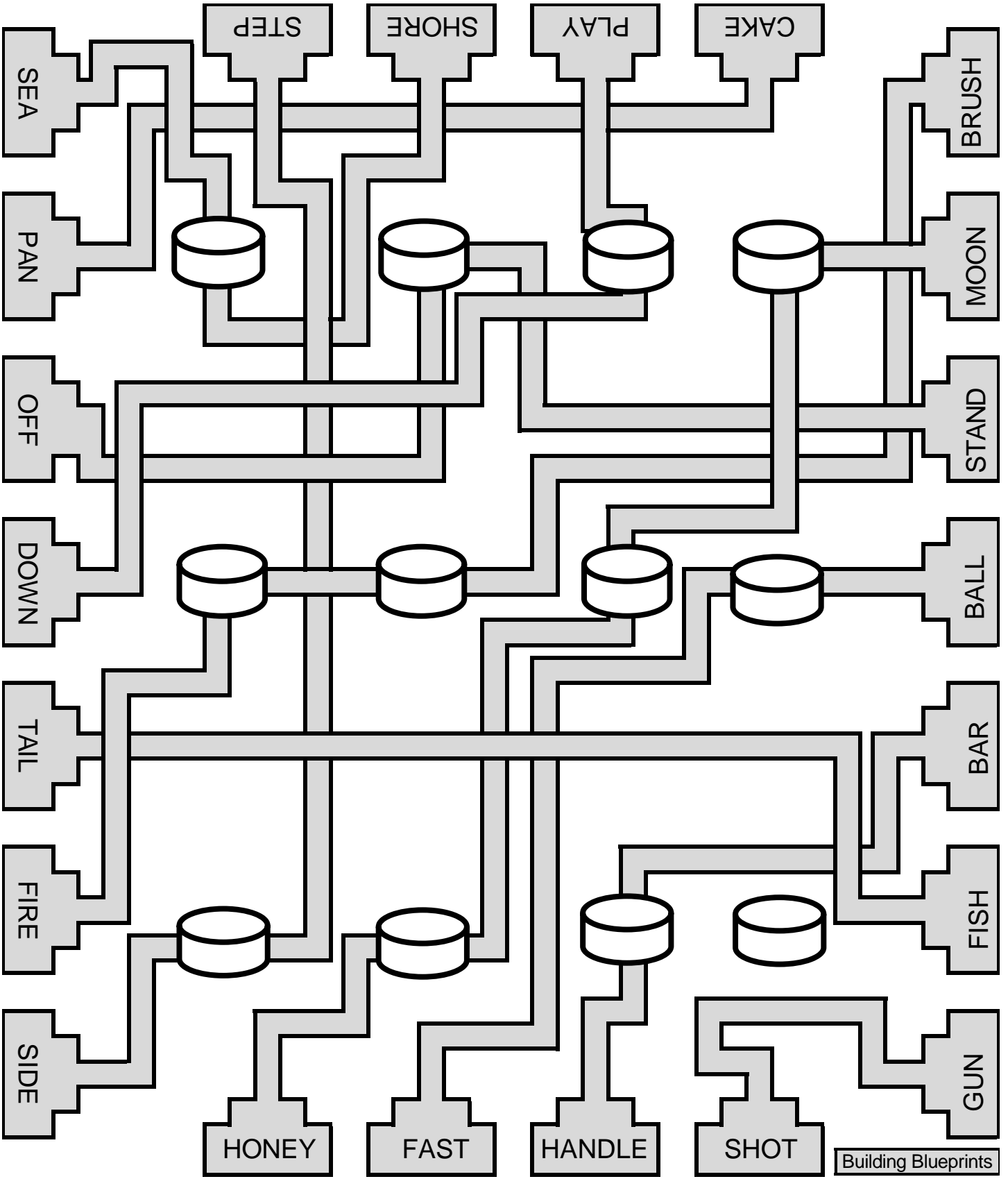

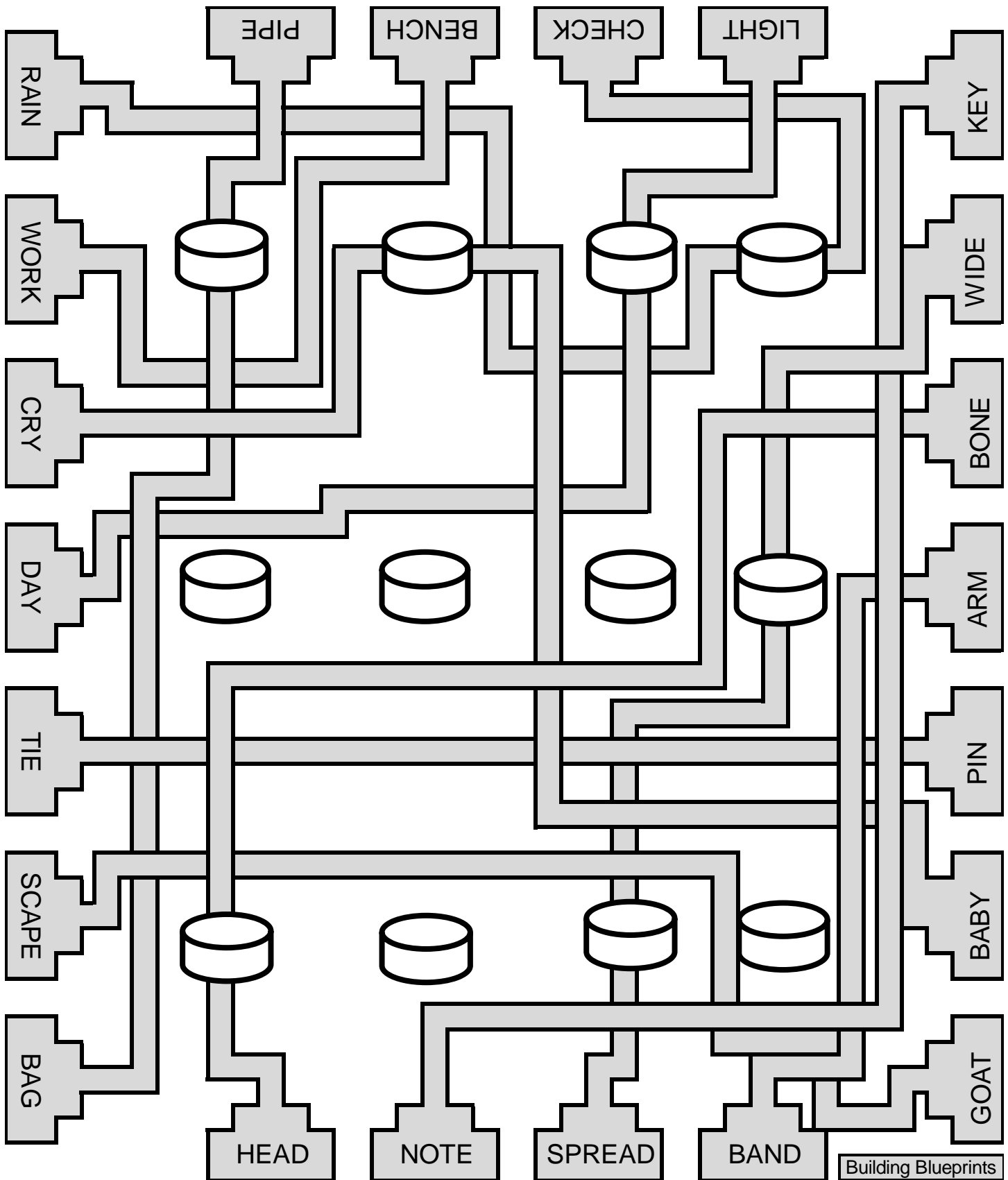

Building Blueprints

